

Distribuidor exclusivo para la República Argentina
 T. 011 4222 5040 - F. 011 4201 2478
 www.tekmatic.com.ar - info@tekmatic.com.ar

SVENDBORG BRAKES, DENMARK
 CVR / VAT: 13256438
 WWW.SVENDBORG-BRAKES.COM

REV. A 97226 ROL 30-07-2014
 REV. B 97611 CAS 17-02-2015
 REV. C 98086 RMJ 14-09-2015

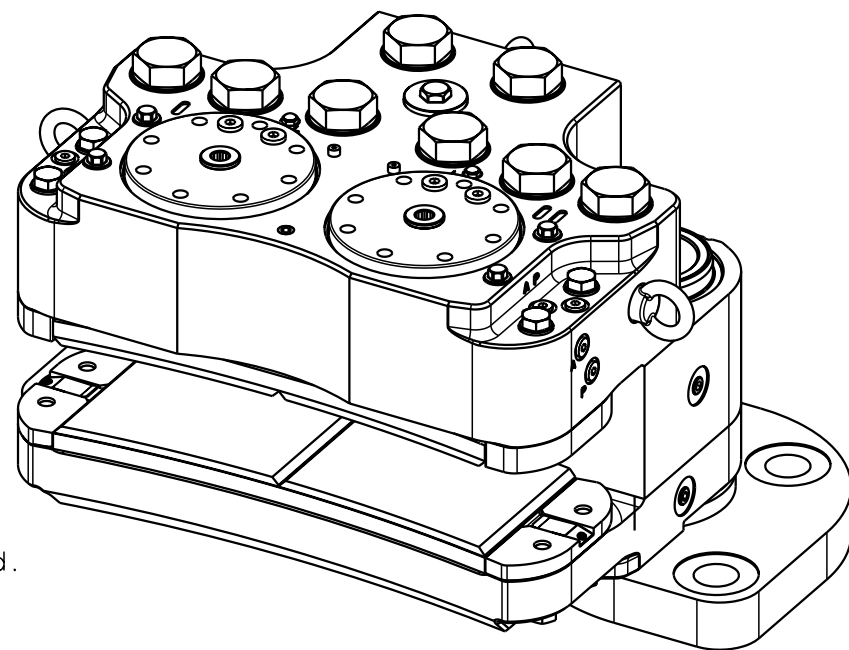
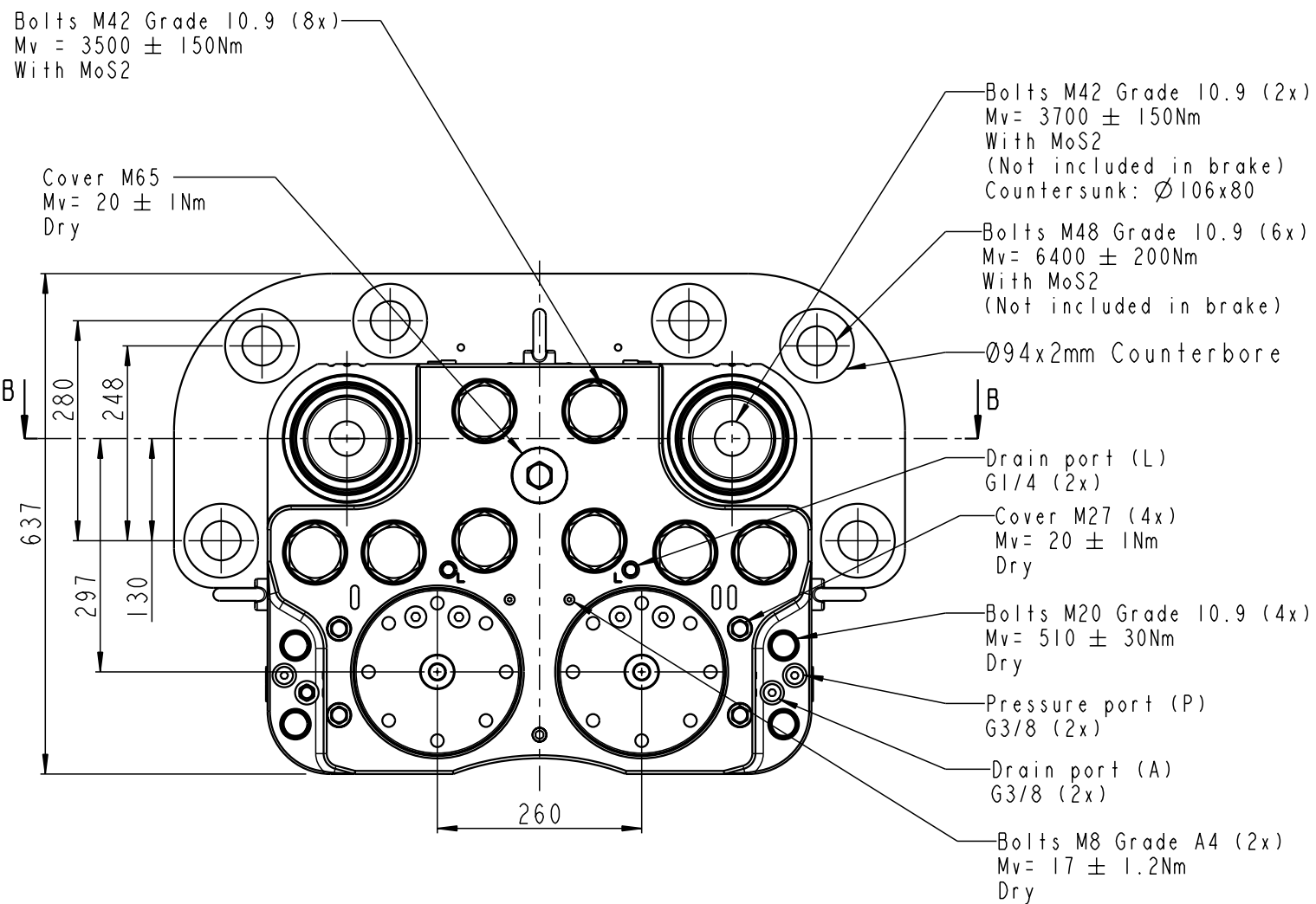
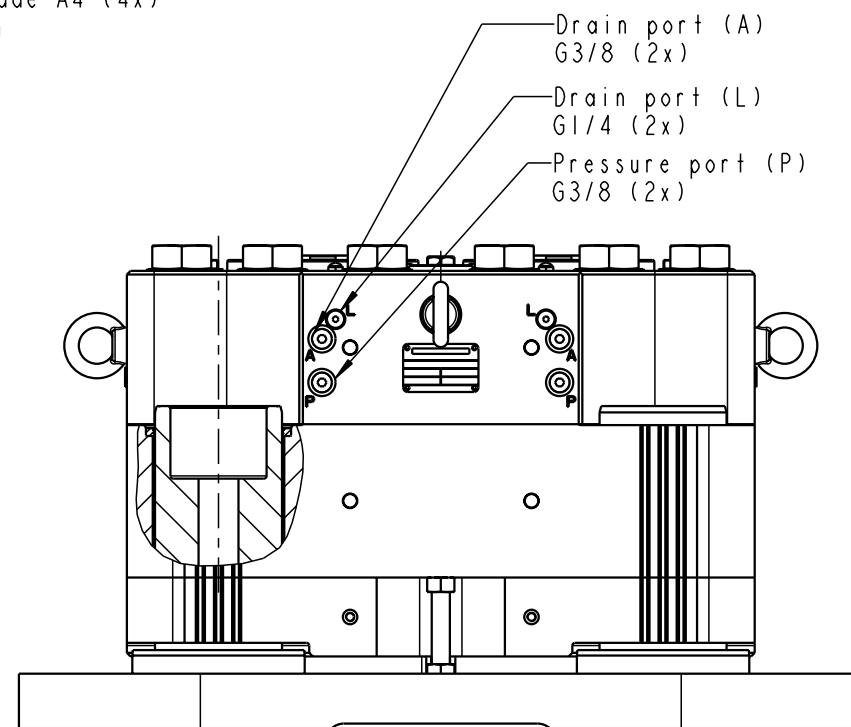
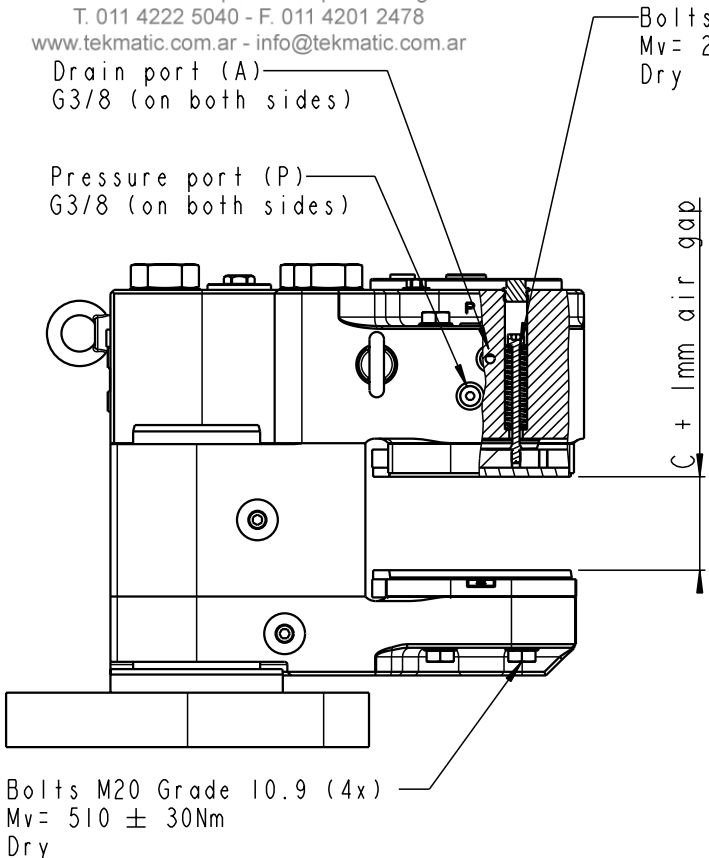
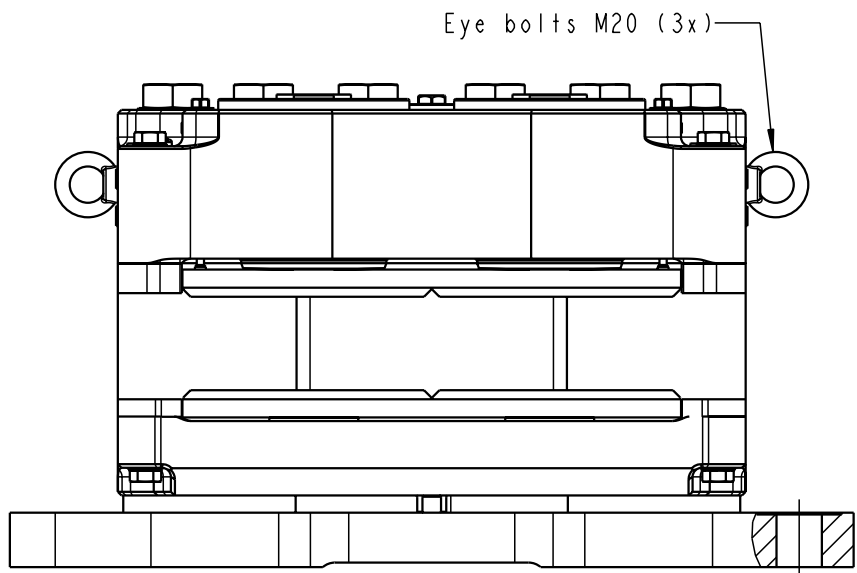

(A)+(L): Drain ports,
 must not be pressurized.
 (P) : Pressure ports.

Brake can move on shafts:
 Without positioning system mounted: 10mm upwards and 5mm downwards from nominal mounting dimension (195)
 With standard positioning system mounted: 1mm upwards and 1/2 air gap downwards from nominal mounting dimension (195)

C = Brake disc thickness (From 32 to 102mm depending on spacer thickness)
 Mounting data, see drawing: 490-5402
 Weight: Approx. 910-1000 kg incl. brake pads

TOLERANCES FOR INTERNAL AND EXTERNAL RADII, ANGLES AND CHAMFERS ACCORDING TO:		ALL DIMENSIONS IN mm	DRAWING STATUS
ISO 2768 - mK		DESCRIPTION	Released
DRAWN BY RMJ			
DATE 05-06-2014		BSFH D500-XXX-MSXXX-102	REVISION C
		DRAWING NO.	SCALE 3:25 (A3)
		490-4910	SHEET 1 OF 1 SHEETS